

*Compact  
Wheel Loader*

**HYDRA Robotica**

Headquarter  
Via Guiccioli 6  
40062 Molinella (BO) – Italy

T: +39 051 6908660  
E: info@hydrarobotica.com



**JDX I**



[www.hydrarobotica.com](http://www.hydrarobotica.com)

**HYDRA ROBOTICA**

MADE IN ITALY



## Description:

The loader JOX I is a hydraulic **remote control** wheel loader. The robot is powered by engine or an electric powerpack which is positioned in the back of the loader. The loader do not require connecting cables. The loader is designed in order to handle different tools such as bucket, forklift and others. The loader is supplied with its container office to control remotely the robot operation.

## Features:









- TELESCOPIC BOOM
- FOAMED WHEELS
- FRONT BUCKET
- HYDRAULIC POWERED
- REMOTE CONTROL
- VIDEOCAMERA (ANDROID & IOS)
- LED WORKING LIGHT
- LIFTING RING

## Application fields:

- TANK CLEANING
- MINING
- CONFINED SPACES
- TUNNEL



## Technical Features:

	2600 x 1310 x 1450		Q=40lt/min;P= 160 bar
	24Volt		300 lt
	25 KW from hydraulic powerpack		1400kg
	10 km/h		Wifi camera & LED lighs



## Dimensions:

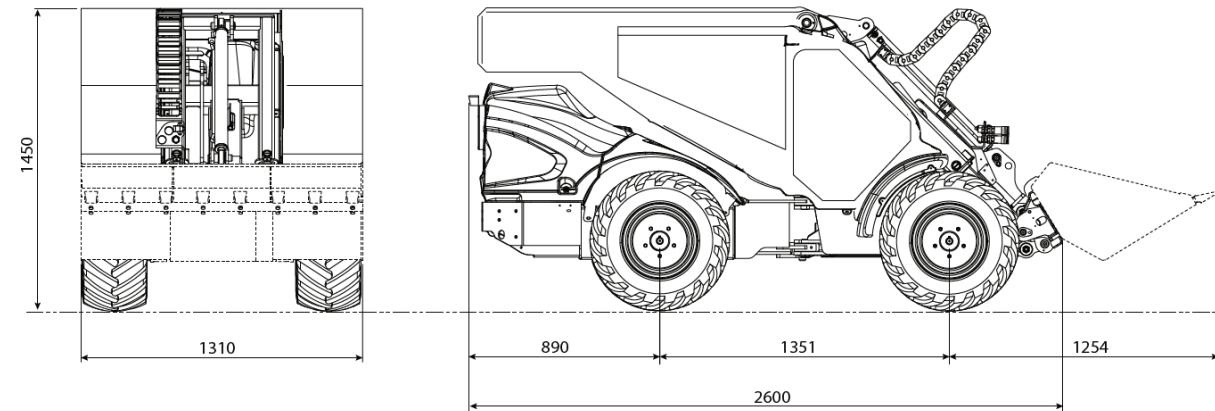

## Accessories:



Bucket



Bucket with pump



Forklift



Pipe cutter



Remote Control



Hydraulic hose reel